



NANO GRILL F-2 SMOKELESS

COMMERCIAL COOKING APPLIANCE

VOLTAGE 120V, 60Hz
Single Phase, 1,500W
Automatic Timer for 60min.
15AMP Dedicated Circuit

- 1
- 2
- 3
- 4
- 5

CLEAN & ODORLESS ENVIROMENT
NO MORE SMOKE & CHARRED MEAT
ECO-FRIENDLY PRODUCTS
SAVE ENERGY & COSTS
UL CERTIFIED PRODUCTS



NANOTECH, INC.

Table of Contents



Safety Information ----- 1p

How to use

Product Maintenance and Checkout ----- 2p

Product Specification ----- 2p

Before using

Electricity ----- 3p

Assembly Order ----- 4p

Re-assembling after cleaning ----- 5p

Product Size ----- 6p

Safety Information

This information is to secure the user's safety and handle this product with safety and to prevent any property damages by preventing accidents caused by the user's fault.



Warning

Death or serious wound might occur if you don't follow the information.



Caution

Damager on human bodies or property loss might occur if you don't follow the information.



120V

This product operates only on 120V rated voltage.



Product Maintenance and Handling



when you handle the product, unplug it and put on gloves.
 Damages from electric shock and burns might occur.
 Handle the product after it cools down completely.



Don't Do not disassemble, fix, or remodel this produce on your own.
 Do not let this product be disassembled, fixed, and revised by others who are not the authorized service man.
 Damages caused by overheating and malfunction might occur.



Don't Do not spread water
 Do not water the surface of the product. This might cause short circuit, electric shock, and fire.



Don't Do not use flammables like thinner or benzene in cleaning.
 Flammables like thinner or benzene used for cleaning might cause combustion.



When you handle the product, unplug it and put on gloves.
 Damages might occur without gloves.

Product Specification

Type	Specification	Table Holes
Model	GRILL-F2	<p>Diagram showing a circular hole with diameter 360mm and a rectangular hole with width 100mm and height 220mm. The distance between the two holes is 25mm.</p>
Electricity Voltage	Single-phase current 120V, 60Hz	
Electricity Output	1500W	
Time	Automatic Timer for 60 min	
Weight	14Kg	

Electricity

Warning This product operates only on 120 volts. Plug in into an electric outlet of 120 volts over 15A

Make sure that the electricity volts are equal to the description on the sticker on the bottom. Be aware of the risk of electric shock and fire.



Warning Do not use a loose outlet or the plug when the electric cord is damaged from shocks.

Be aware of the risk of electric shock and fire.

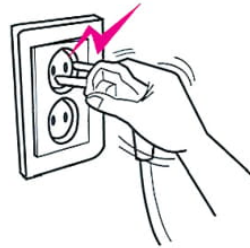

Don't Do not touch the electric plug with wet hands.

Be aware of the risk of electric shock and fire.

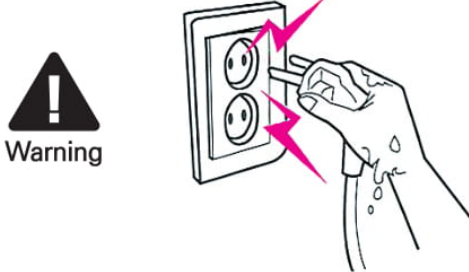

Warning

Don't Do not touch by pulling the electric cord.

Be aware of the risk of electric shock and fire.

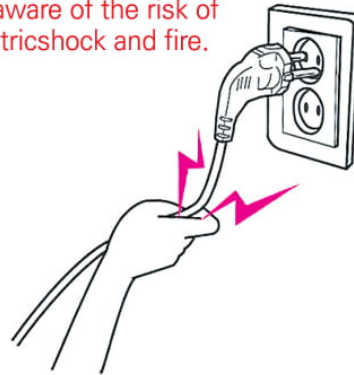

Don't Do not put the product on fire without setting up the roasting plate. Do not use this product for the purpose of heater.

This might cause fire and malfunction



Warning Make sure that the plug is free of attachments and push it down to the end of the outlet.

Be aware of the risk of electric shock and fire.

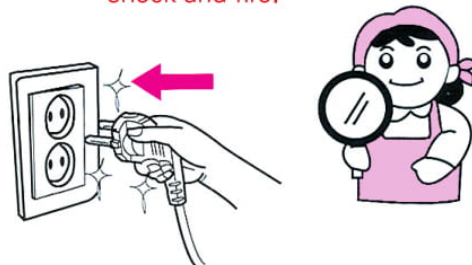

Assembly Order



Re-assembling after cleaning



Product Size

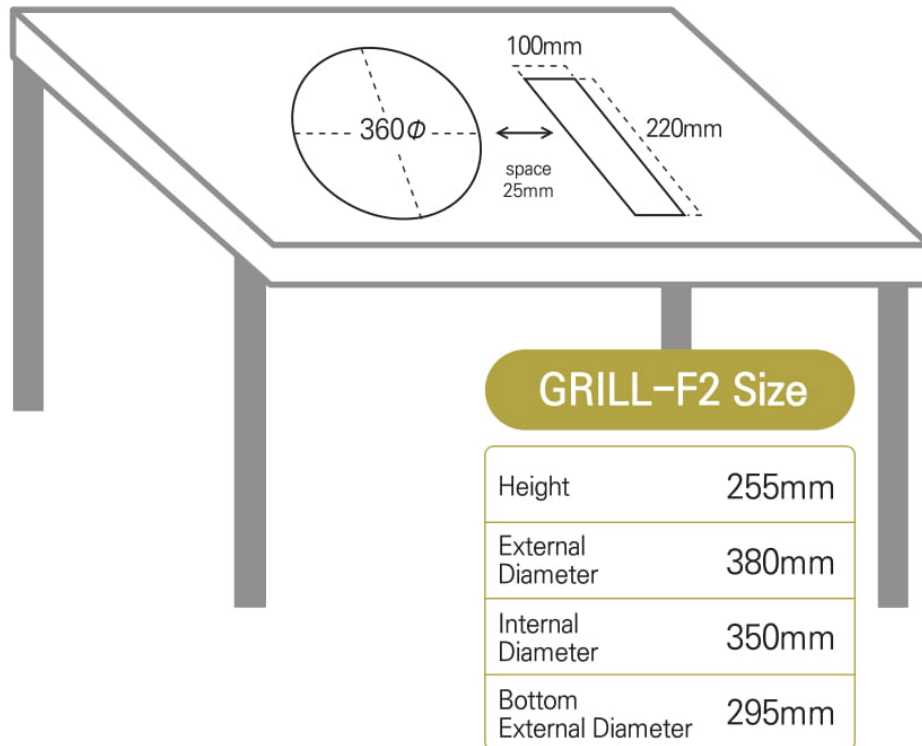

How to set up a table

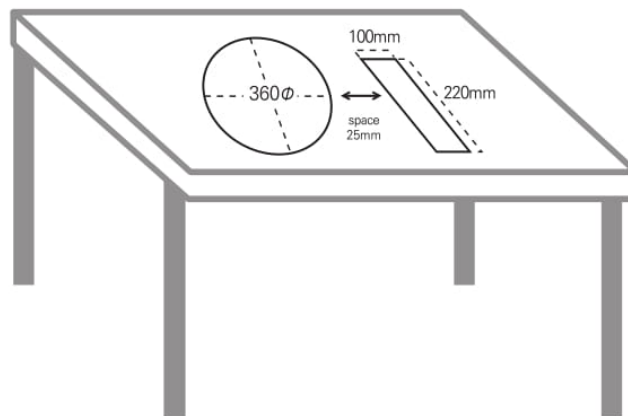

1. put the parts in the order of ④,③,②,① into 360φ

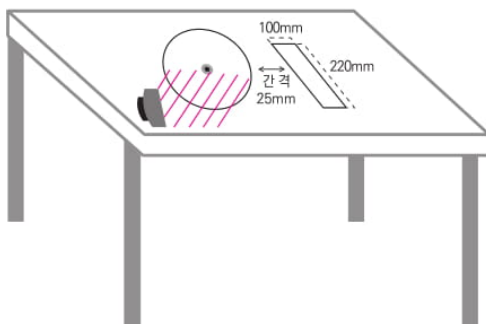

2. Fix the ② Motor into the body.

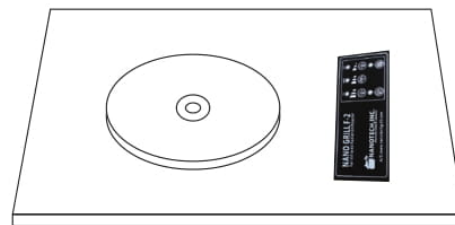

3. Set up the empty control box from the table bottom toward the surface.

4. Fix the converter box from the table bottom with bolts.

CLEANING

WARNING: To avoid electrical shock, never clean grill inside with plugged into an outlet or turn on.

CLEANING THE NANO WELLBEING GRILL F-2 / INSIDE COMPARTMENT

1. The Nano wellbeing grill F-2 / inside grill compartment base, side back panel can be cleaned using multipurpose disinfectant cleaner with warm soapy water and a nonabrasive or soft cloth by weekly. Ensure that the manufactureres instructions are followed and that all parts are well rinsed afterwards. Uncleaning inside grill can cause product defects.

2. Switch off the grill from he electricity supply before cleaning(water/soap) and ensure **the grill is cold.**

3. Gently replace the ramp to allow access to the grill. **DO NOT FORCE** the element to open or remove. Use right size screw or tools and gently push the grill element back into place after ramp replace. Handle caefully for glass part with cotton gloves. Please check YOUTUBE VIDEO instruction!

4. Replace Fuze repeat as same as above. (250V 15AMP) Please check YOUTUBE VIDEO instruction!

Ensure the screw is firmly in place after cleaning or replacing part.

WARRANTY INFORMATION

PRODUCT COVERED	All Parts, One Year Unlimited Warranty.
WARRANTY PERIOD	One year from the product purchase date until the first anniversary of the product purchase date.
WARRANTY COVERAGE	Defects in materials and workmanship under normal use.
WARRANTY EXCLUSIONS	Normal wear and tear or misuse/abuse or modification of the product. <i>*Service/Shipping & Handling Charge may applies when warranty expires.</i>
PROOF OF PURCHASE REQUIRED	YES

This warranty is provided by Nano wellbeing grill(USA) to the original purchaser who purchased the product from an authorized dealer of Nano wellbeing grill F-2. This warranty is not transferable. Unless prohibited by applicable law, this warranty does not apply to products purchased from unauthorized sellers, including auauthorized internet sites. In order to process a warranty claim that is field, we require a proof of purchase and images of the damaged product. This warranty gives you specific legal rights, and you may also have other rights which vary from State to State. If you need assistance related to warranty matters, please go to official website(<http://nanotechgrill.com>) or communicate with us at Nano Wellbeing Grill(USA), 18623 Hwy 99, ste 220 Lynnwood, WA 98037, 425-582-9327 to file a warranty claim.





Simple and Easy Installation

<https://www.youtube.com/watch?v=p3Wgpzz-NUo>

Detailed Specifications and Dimensions

COMMERCIAL COOKING APPLIANCE NANO GRILL F-2

PRODUCT	F-2
RATED VOLTAGE	Single-phase alternating current 120V, 60Hz 20AMP Dedicated Circuit
WATTAGE	1,500W
TIMER	60 Minute Automatic Timer Feature
PRODUCT WEIGHT	approx. 26.5lbs
GRILL SIZE	14.173in



<https://nanotechgrill.com/>

Nano Well-Being Grill (USA)

18623 Hwy 99, Ste 220 Lynnwood, WA 98037 / Tel. 425-582-9327

NANO WELL BEING GRILL

"WE THINK GREEN"

ECO FRIENDLY COMMERCIAL
COOKING APPLIANCE



■ This product is Listed by UL. Representative samples of this product have been evaluated by UL and meet applicable safety standards.

"Using Nano-carbon lamp that generates far infrared rays in a large quantities it gives clean and comfortable room air without smoke".



CLEAN & ODORLESS
ENVIRONMENT



ECO-FRIENDLY
PRODUCTS



NO MORE SMOKE
& CHARRED MEAT



SAVE
ENERGY & COST



OUR STORY

NANOTECH, Inc. was established in 1980 as commercial kitchen appliance specialist and developed into a more specialized roasting and grilling product company using eco-friendly methods and technology.

NANOTECH, Inc. was formed with a great ambition, "Cleaner Earth, Every Day."

With 7 years of countless efforts and devotions, we invented the Nano WellBeing Grill, the only UL approved grill that does not create carbon monoxide and carbon dioxide.

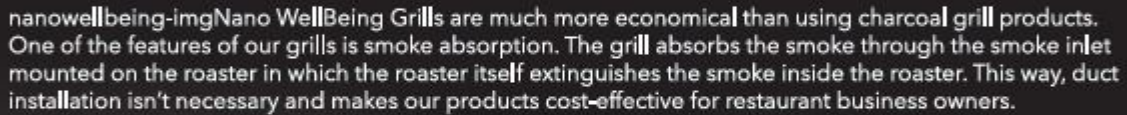
nanowellbeing Nano WellBeing Grills are much more economical than using charcoal grill products. One of the features of our grills is smoke absorption. The grill absorbs the smoke through the smoke inlet mounted on the roaster in which the roaster itself extinguishes the smoke inside the roaster. This way, duct installation isn't necessary and makes our products cost-effective for restaurant business owners.

We will continue to do our best contributing to our customers and society and to continue research and development of energy-saving and environment-friendly products to become a company that our consumers can trust.

NANOTECH, Inc.

NANO GRILL F2 FAN

Smokeless
Odorless
No Duct Needed
Save Energy & Costs

INFRA-RED Light

Naturally Sterilize
Deodorize
Taste without Drying out

HIGH QUALITY GRILL PAN

Coated with 5
Special
Teflon Coating
Easy Detachable
and Clean

*More Pan available at Our Website

COMMERCIAL COOKING APPLIANCE

NANO GRILL F2



SAVE ENERGY & COST

We will continue research and development of energy-saving, environment-friendly products to high oil prices. Nano Well-Being grills remove the smoke through the intake. There is no need an internal ductwork.



CLEAN & ODORLESS ENVIRONMENT and ECO-FRIENDLY PRODUCTS

To all business owners, health is also a very important factor. We provide products that prevent tar and fumes and create an eco-friendly environment. Our grills don't use charcoal in order to maintain clean air without smoke.



NO MORE SMOKE & CHARRED MEAT

Juicy and Savory Flavors
Infra-red is stronger than charcoal so it has a feature to naturally sterilize and deodorize. The grill preserves the taste without drying out the meat while cooking the inside and outside at the same time.



UL LISTED CERTIFIED

This product is Listed by UL. Representative samples of this product have been evaluated by UL and meet applicable safety standards.



THERMAL SENSOR TEMPERATURE DISPLAY

Automatic Sensor! Automatic 60-minute Timer Application! The temperature display allows comfort and is easily detachable for wash. No need to manually control between high, medium, and low heat. The sensor automatically switches back and forth between medium and high heat.

