

ECO-FRIENDLY SMOKELESS NANO GRILL F-2™ "WE THINK GREEN"

SPECIFICATIONS DIMENSIONS & OWNER'S MANUAL

COMMERCIAL COOKING APPLIANCE

VOLTAGE 120V, 60Hz
Single Phase, 1,500W
Automatic Timer for 60min.
20AMP Dedicated Circuit



CLEAN
ENVIRONMENT



ECO-FRIENDLY
PRODUCTS



NO MORE SMOKE
& CHARRED MEAT



SAVE
ENERGY
& COST

"By utilizing a Nano-carbon lamp that generates a large quantity of far-infrared rays, this technology provides clean and comfortable room air without smoke."

COMMERCIAL COOKING APPLIANCE NANO GRILL F-2™

PRODUCT	F-2™
RATED VOLTAGE	Single-phase alternating current 120v, 60Hz 20AMP Dedicated Circuit
WATTAGE	1,500W
TIMER	60Minute Automatic Timer Feature
PRODUCT WEIGHT	approx. 26.5lbs
GRILL SIZE	14.173in 

**PATENT IN
REPUBLIC OF KOREA
US PATENT PENDING**

**TRADEMARK IN
REPUBLIC OF KOREA
TRADEMARK IN US**



<https://nanotechgrill.com/>
Nano Well-Being Grill (USA)
18623 Hwy 99, Ste 220 Lynnwood, WA 98037
Tel. 425 582 9327



NANOTECH, INC.
NANO WELLBEING GRILL

Safety	Page 4
Diagrams	Page 5
Installation	Page 6, 7 & 8
Operation	Page 9
Maintenance	Page 10
Warranty	Page 11
Specification	Page 12
Troubleshooting	Page 13
Certification	Page 14

1. SAFETY

To avoid damage or danger by improper use, this instruction manual should be read and followed carefully. Save the instruction manual together with the warranty information and receipt for further reference. If you give the appliance to another person, also supply them with this instruction manual.

The safeguards must be followed closely, and the appliance must be used in the way indicated in the instruction manual. In case of damage and accidents caused by not following this instruction manual, manufacturer assumes no liability.

When using electrical appliances, basic safety precautions should be followed, including the following:

Warning – To reduce the risk of burns, electric shock, fire, injury to persons, or exposure to excessive electromagnetic energy:

1. Read all instructions before using the appliance.
2. This appliance must be grounded. Connect only to properly grounded outlet.
3. Use this appliance only on the specified electrical circuit.
4. Install or locate this appliance only in accordance with the provided installation instructions.
5. Use this appliance only for its intended use as described in the manual. Do not use corrosive chemicals or vapors on this appliance.
6. As with any appliance, close supervision is necessary when used by or around children.
7. Do not operate this appliance if it has a damaged cord or plug, broken or cracked glass surface, if it is not working properly, or if it has been damaged or dropped.
8. This appliance should be serviced only by qualified service personnel. Contact Nanotech for the authorized service facility for examination, repair or adjustment.
9. Do not cover or block any openings on the appliance.
10. Do not place the range in, on or near open flames, electric burners, ovens or other high temperature surroundings.
11. Do not touch the range while cooking or while hot.
12. Do not store this appliance outdoors.
13. Do not use this product near water.
14. Do not immerse cord or plug in water.
15. Keep cord away from heated surfaces.
16. Do not let cord hang over edge of table or counter.
17. Do not touch the hot surface of the grill cooktop.

2. DIAGRAMS

Pre-Assembled Parts



1. Grill Body
2. Fan Motor
3. Control Panel
4. Power Converter

Removable Parts - Cleaning required after use



<https://nanotechgrill.com/>
Nano Well-Being Grill (USA)

18623 Hwy 99, Ste 220 Lynnwood, WA 98037 / Tel. 425-582-9327

3. INSTALLATION

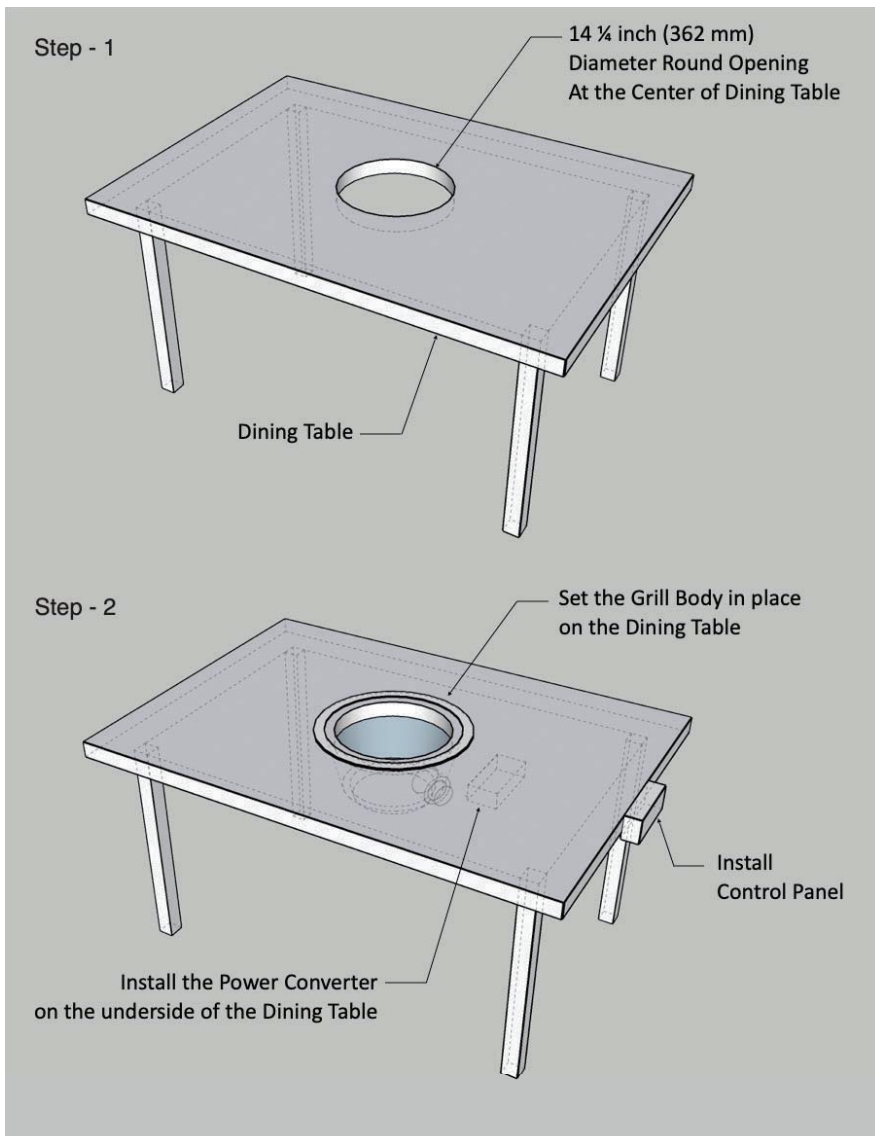

<https://nanotechgrill.com/>

Nano Well-Being Grill (USA)

18623 Hwy 99, Ste 220 Lynnwood, WA 98037 / Tel. 425-582-9327

3. INSTALLATION - Continues

Step – 3 : Install all parts into the Grill in the order of the numbers.

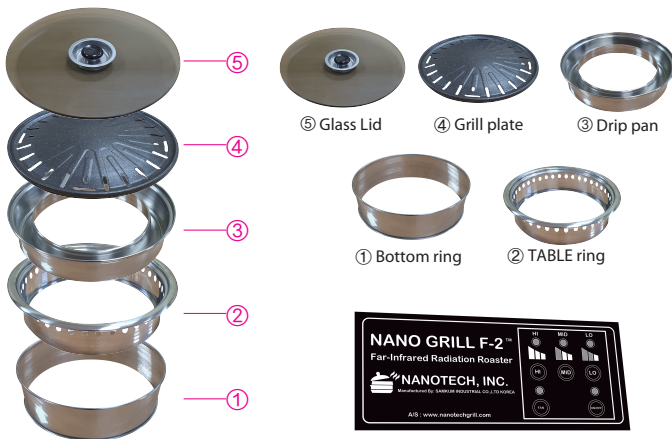

1 Set the Grill Body in Place on the Dining Table



2 Place the Bottom Ring inside the center of the Base Unit.
*** Ensure that the hook on the Bottom Ring is on the top and not the bottom.**



3 Place the Table Ring on top of the Bottom Ring inside the Base Unit.

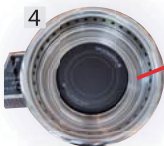

4 Install the Drip Pan
Fill with water to ~1 inch

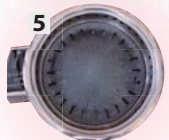

5 Place the Grill Plate

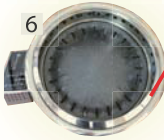

6 When cooking without the Glass Lid, place the Oil Splatter Guard Ring on top of the Grill Plate(Optional).

3. INSTALLATION - Continues

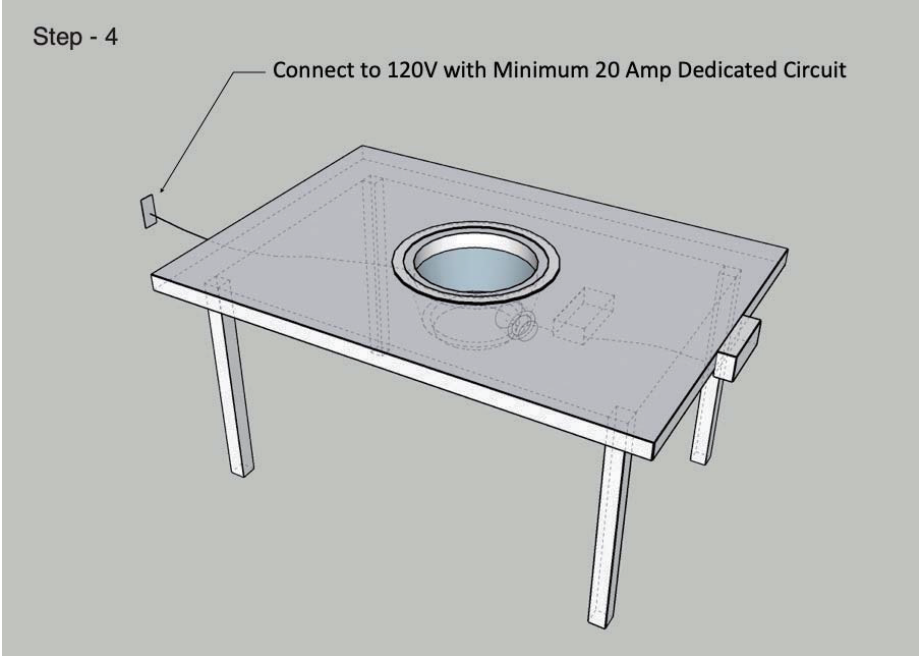

4. OPERATION

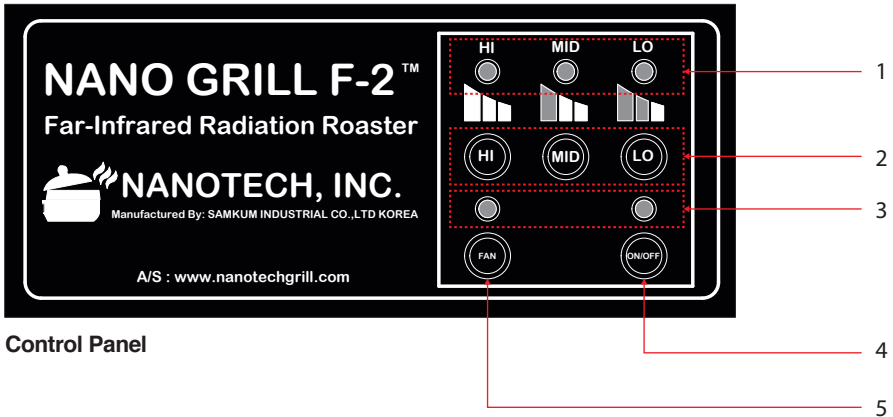

1. LED indicators for Grill Temperature Levels
2. Grill Temperature Switches : High / Medium / Low
3. LED Indicators
4. Grill On / Off Switch
5. Fan Switch

- The grill will not operate without the appropriate installation of all components. Refer to page 6 - Installation
- If the temperature of the cooktop reaches 260 C or 500 F, the unit turns off automatically and displays an error code. Allow the unit to cool off for 10 minutes. Restart by pressing power on/off button.
- If the voltage or current in the device is abnormal it will shut itself off.
- 60 Minutes Automatic Timer Installed.

<https://nanotechgrill.com/>

Nano Well-Being Grill (USA)

18623 Hwy 99, Ste 220 Lynnwood, WA 98037 / Tel. 425-582-9327

5. MAINTENANCE

CAUTION! DANGER OF BURNING AND ELECTRIC SHOCK!

- ALWAYS TURN OFF THE GRILL AFTER USE AND BEFORE CLEANING.
- LET THE GRILL COOL DOWN BEFORE CLEANING.

CLEANING THE INSIDE COMPARTMENT

1. Switch off the grill from the electricity supply before cleaning (water/soap) and ensure the grill is cold.
2. All grill compartments inside of the grill body as shown at page 7 shall be cleaned using multipurpose disinfectant cleaner with warm soapy water and a nonabrasive or soft cloth after use.
3. Failure to clean the inside of the grill can result in product defects.
4. Dry all parts after cleaning and install as per this manual. Refer to page 6.
5. When cleaning, use only mild, nonabrasive soaps or detergents applied with a sponge of soft cloth.

6. WARRANTY

PRODUCT COVERED	All Parts, 180-days limited warranty
WARRANTY PERIOD	180-days from the date the product is received
WARRANTY COVERAGE	Defects in materials and workmanship under normal use
PROOF OF PURCHASER REQUIRED	YES

This Limited Warranty does not cover:

1. Equipment sold or used outside the United States
2. Nanotech has the sole discretion on wearable parts not covered under warranty
3. Equipment not purchased directly from an authorized dealer
4. Equipment used for residential or other non-commercial purposes
5. Equipment that has been altered, modified, or repaired by anyone other than an authorized service agency
6. Equipment where the serial number plate has been removed or altered.
7. Damage or failure due to improper installation, improper utility connection or supply, and issues resulting from improper ventilation or airflow.
8. Defects and damage due to improper maintenance, wear and tear, misuse, abuse, vandalism, or Act of God.

Any action for breach of this warranty must be commenced within one year from the date on which the breach occurred. No modification of this warranty or waiver of its terms shall be effective unless approved in writing and signed by the parties involved. This warranty is provided by Nano Wellbeing Grill USA to the original purchaser who bought the product from an authorized dealer of Nano Wellbeing Grill F-2. This warranty is non-transferable. Unless prohibited by applicable law, it does not apply to products purchased from unauthorized sellers, including unauthorized internet sites. To process a warranty claim, we require proof of purchase and images of the damaged product. This warranty grants you specific legal rights, and you may also have other rights that vary from state to state. For assistance regarding warranty matters, please visit our official website (<http://nanotechgrill.com>) and email us.

7. SPECIFICATION

MODEL	F-2™
WATTAGE	1500W
VOLTAGE	120V
HERTZ	60Hz
TEMPERATURE RANGE	Max 500 F
TIMER	60Min. Automatic Timer
CUT OUT DIMENSION	14 1/4" Diameter (362mm)



<https://nanotechgrill.com/>
Nano Well-Being Grill (USA)

18623 Hwy 99, Ste 220 Lynnwood, WA 98037 / Tel. 425-582-9327

8. TROUBLESHOOTING



SCAN THIS QR CODE FOR
TROUBLESHOOTING VIDEO



<https://nanotechgrill.com/>
Nano Well-Being Grill (USA)

18623 Hwy 99, Ste 220 Lynnwood, WA 98037 / Tel. 425-582-9327

9. CERTIFICATIONS

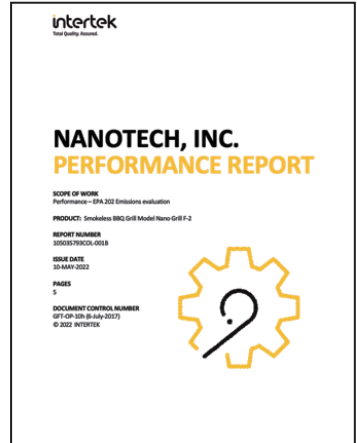
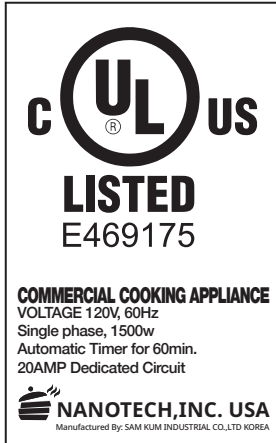

1. UL Listed # E469175

Commercial Cooking Appliance

Tested under *ANSI/UL 197, “Commercial Electric Cooking Appliances.”*

2. INTERTEK Listed #5018095

Commercial Cooking Appliance

Conforms to NSF/ANSI 4

3. INTERTEK Performance Test EPA 202 Emissions evaluation

Condensable Particulate Matter (Revised 12/1/2010) per UL 710B Standard for Recirculating Systems section 59

<https://nanotechgrill.com/>

Nano Well-Being Grill (USA)

18623 Hwy 99, Ste 220 Lynnwood, WA 98037 / Tel. 425-582-9327

ECO-FRIENDLY SMOKELESS
NANO GRILL F-2™
"WE THINK GREEN"



<https://nanotechgrill.com/>
Nano Well-Being Grill (USA)
18623 Hwy 99, Ste 220 Lynnwood, WA 98037
Tel. 425 582 9327